

For Home Cabinet 3 Drawers

Assembly Guide



Model: 3500001553 / 3500001565 / 3500001566

1000012239 - 08/09/2020



it→be

Perfectly
Funtional.

In order to ease the assembly, you should separate and identify the parts first

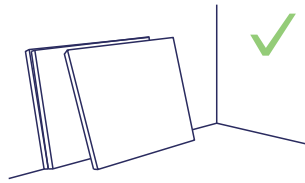
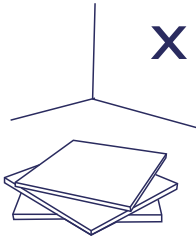

Do not place the parts directly onto the floor. Use a cardboard sheet or a mat to place the parts, during the separation and assembly.

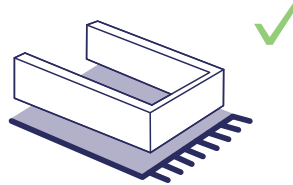
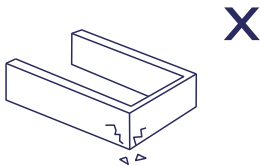

Tools Needed (not supplied)

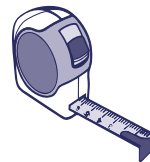
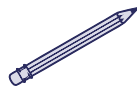
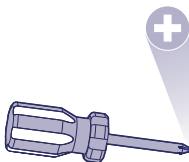

IDENTIFICATION OF PARTS

Nº	DESCRIPTION	IDENTIFY THE COLOR OF YOUR CABINET					DIMENSION		
		BLACK MATTE	WHITE MATTE	GREY	MATERIAL	QUANTITY	LENGTH	WIDTH	THICKNESS
P1	RIGHT SIDE	3000010643	3000010563	-	STEEL	1 PC	29,96"	18,21"	1,82"
P2	LEFT SIDE	3000010642	3000010562	-	STEEL	1 PC	29,96"	18,21"	1,82"
P3	CEILING	3000010641	3000010561	-	STEEL	1 PC	30,26"	18,11"	1,38"
P4	REAR	3000010640	3000010560	-	STEEL	1 PC	30,26"	18,11"	1,38"
P5	BOTTOM BACK	3000010592	3000010469	-	STEEL	1 PC	27,50"	13,56"	0,57"
P6	TOP BACK	3000010633	3000010539	-	STEEL	1 PC	27,50"	13,56"	0,57"
P7	DRAWER'S RIGHT SIDE	-	-	3000010672	STEEL	3 PC	16,14"	6,79"	0,73"
P8	DRAWER'S LEFT SIDE	-	-	3000010671	STEEL	3 PC	16,14"	6,79"	0,73"
P9	DRAWER'S BACK	-	-	3000010673	STEEL	3 PC	26,45"	6,79"	0,73"
P10	DRAWER'S BOTTOM	-	-	3000010669	STEEL	3 PC	26,41"	16,22"	0,40"
P11	DRAWER'S FRONT WITH LOCK	3000010647	-	3000010555	STEEL	1 PC	27,36"	8,82"	0,98"
P12	DRAWER'S FRONT	3000010646	-	3000010552	STEEL	2 PC	27,36"	8,82"	0,98"

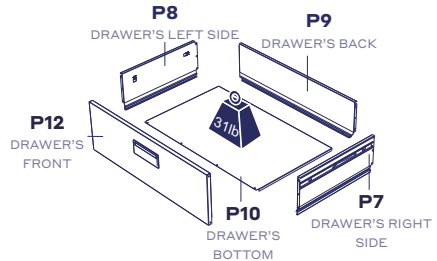
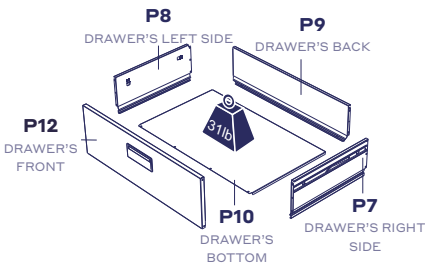
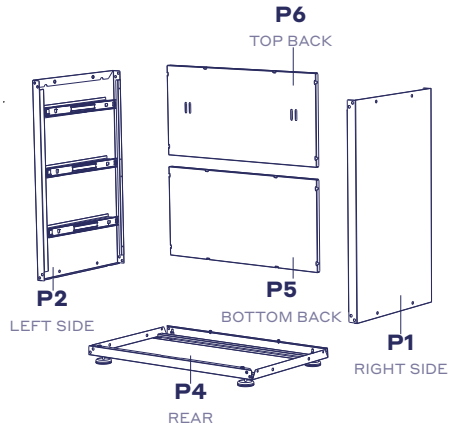
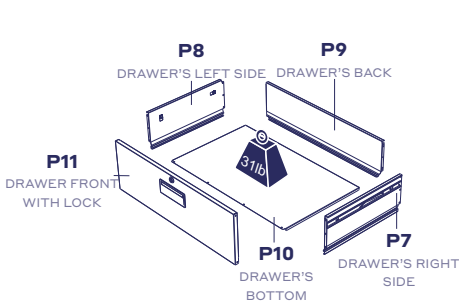

Warning - Maximum distributed weight supported.

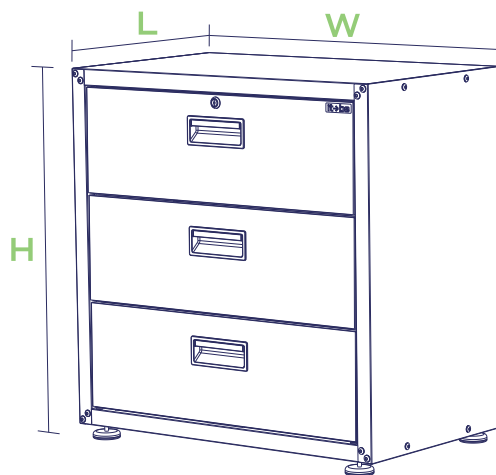

Assembled product:

H:32.3" W:30.3" L:18.1"

Hardware list

F1

1000011853



SCREW M8X12
Qty. 24

F2

1000011851



NUT M8
Qty. 24

F9

1000008368

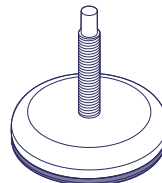

Qty. 4

F13

1000011850

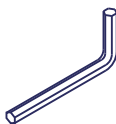

HEXAGON 5mm
Qty. 1x

F15

1000010159



Qty. 1x

F18

1000011849



SCREW 4,8 X 9,5mm
Qty. 57



Locking nut, no key tightening required.

STEP 1

- 1 - Fit the **REAR** inside part **LEFT SIDE** and **RIGHT SIDE**.
- 2 - Align the two holes in the corners and screw **F1** and **F2** to it.

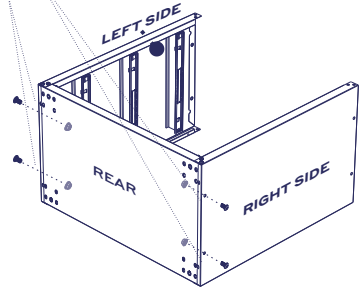
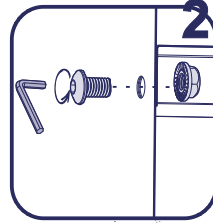
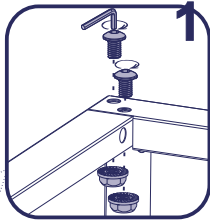
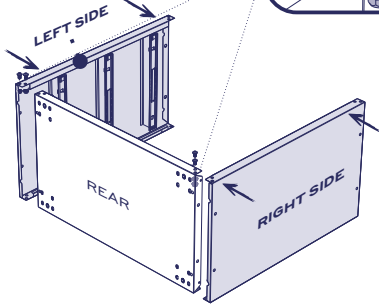
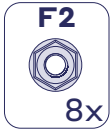

STEP 2

- 1 - Fit the **CEILING** inside part **LEFT SIDE** and **RIGHT SIDE**.
- 2 - Align the two holes in the corners and screw **F1** and **F2** to it.

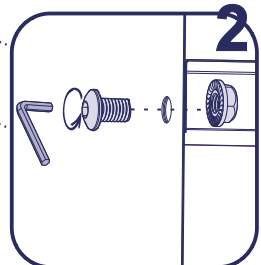
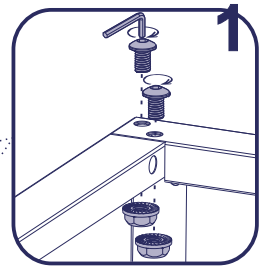
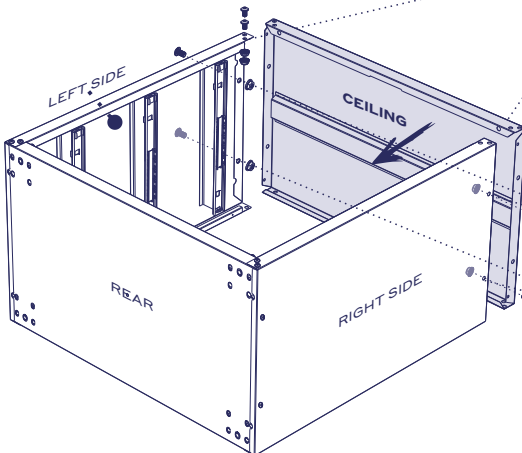
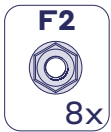

STEP 3



1 - Turn the cabinet with the back side upwards.

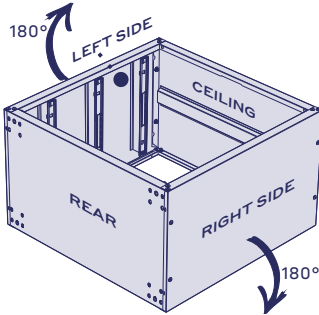
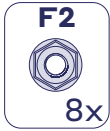

2 - Align the holes and screw F1 and F2 to it to each corners.

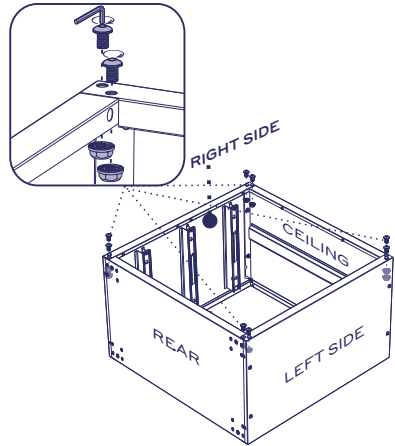

Important -

Check if all parts are correctly positioned to ensure product alignment.

STEP 4

- 1 - Fit the **TOP BACK** into the **RIGHT SIDE**, **LEFT SIDE** and **CEILING**. Check if all parts are supported over the bolts holes.
- 2 - After fitting the parts, screw the bolts until locked.

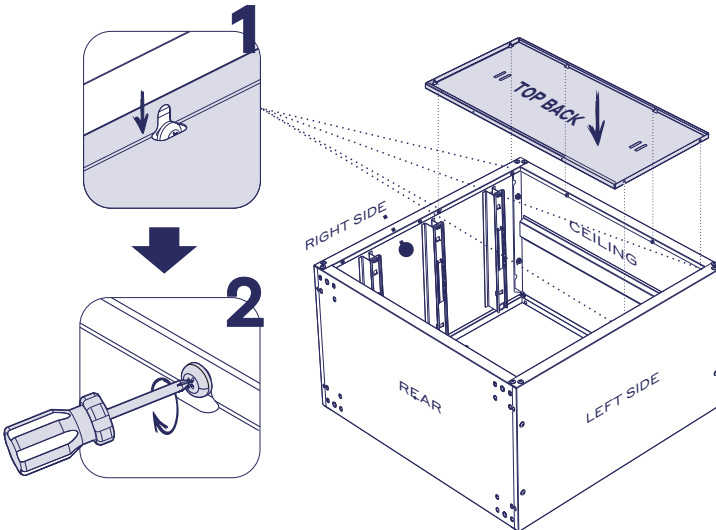

Important

Position part P10 on the P5 side to assemble the cabinet.

STEP 5

- 1 - Fit the **BOTTOM BACK** into the **RIGHT SIDE**, **LEFT SIDE** and the **REAR**. Check if all parts are supported over the bolts holes.
- 2 - After fitting the parts, screw the bolts until locked.

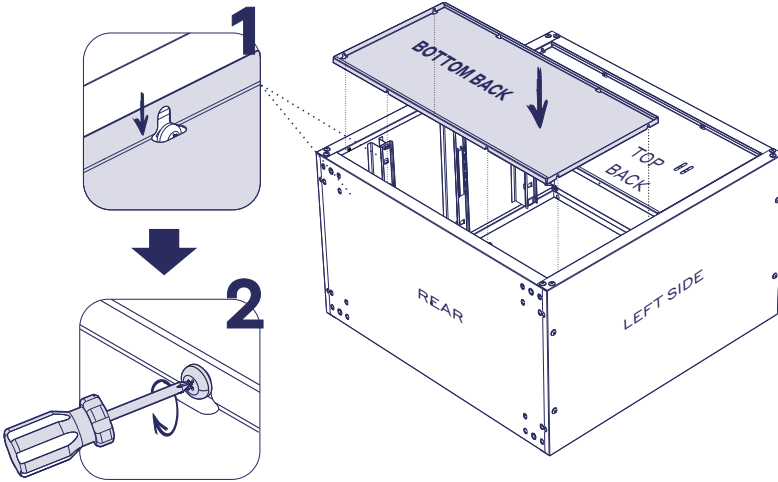

STEP 6

- 1 - Screw the leveling leg **F9** into each of the four rivet nuts located at the corners of the cabinet as shown. To level the height of the cabinet, turn the Leveling Leg either clockwise or counterclockwise to align it.

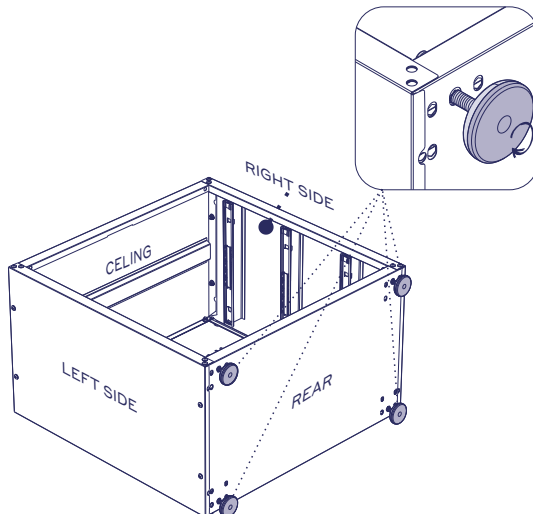

STEP 7

- 1 - Fit the **DRAWER'S BOTTOM** in the **DRAWER'S FRONT** or **DRAWER'S FRONT WITH LOCK**.
- 2 - Screw the two parts with **F18**.

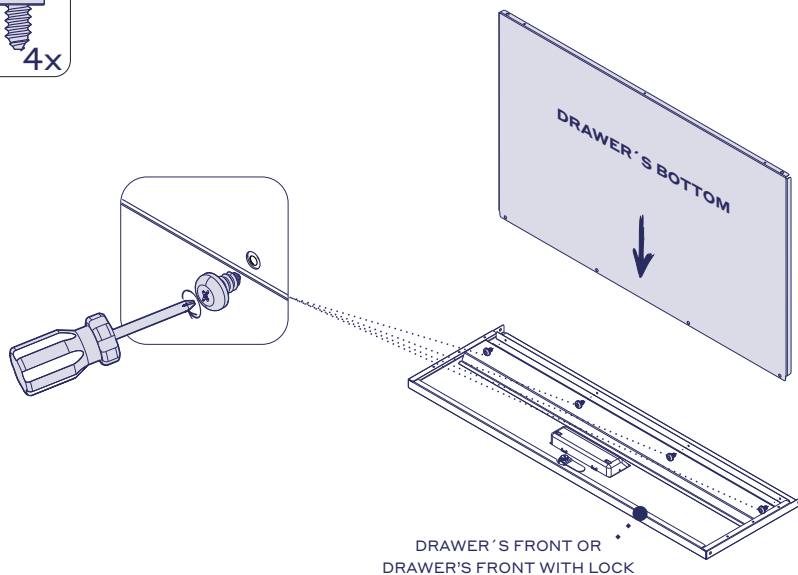

STEP 8

- 1 - Align the **DRAWER'S RIGHT SIDE** and **DRAWER'S LEFT SIDE** to the **DRAWER'S BOTTOM**, until it fits the **DRAWER'S FRONT**.
- 2 - Screw them with **F18**.

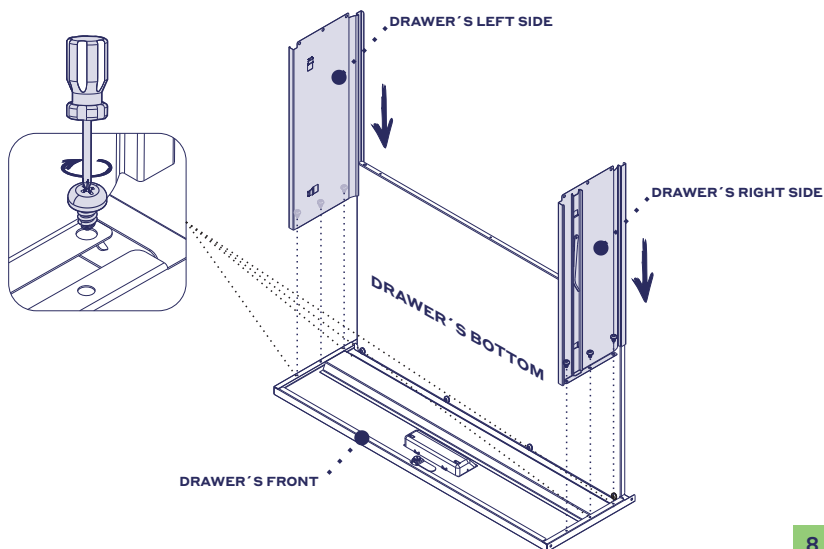

STEP 9

- 1 - Insert the **DRAWER'S BACK** over the **DRAWER'S BOTTOM** and between the **DRAWER'S RIGHT SIDE** and **DRAWER'S LEFT SIDE**.
- 2 - Then, screw the **DRAWER'S BACK** to the **DRAWER'S RIGHT SIDE**, **DRAWER'S LEFT SIDE** and **DRAWER'S BOTTOM**, with **F18**.

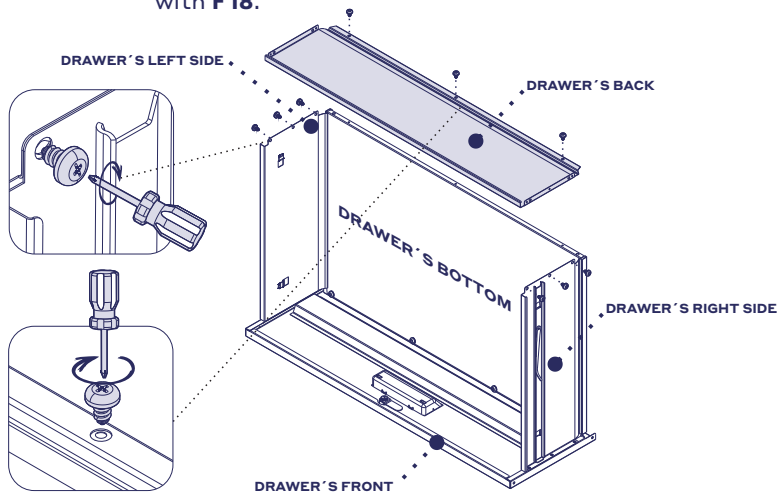

STEP 10

- 1 - Fit the drawers - already assembled - between parts **SIDES**, through the drawer slides.
- 2 - Check if the drawer slides on both sides are properly fitted. If they are not properly fitted, the drawer will not close completely. Slide the drawer in and out to test it and be sure it is sliding smoothly.

- 2 - The procedure for removing the drawer is illustrated above.

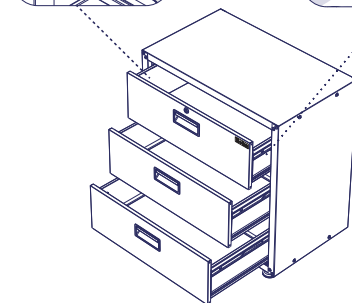
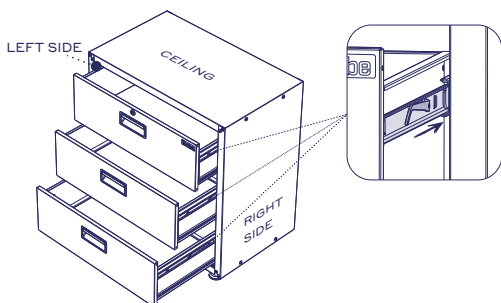
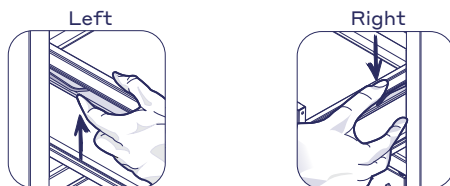

Important -

Repeat this steps to assemble the other two drawers.



WARRANTS TERMS AND CONDITIONS

ITBE PRODUCTS

This document describes the limited warranty agreement ('Warranty') regarding your purchase of ITBE's furniture and/or equipment ('Product') within USA territory. This agreement is subject to the conditions described below.

1. WARRANTY SCOPE

- 1.1.** This Warranty covers Product defects resulting from defective parts, materials or manufacturing, if such defects occur during the period of 12 months after the date of purchase.
- 1.2.** The Products are considered defective if they fails to perform the functions as indicated in the operation manuals, technical specifications or any other similar documents supplied with the Products, and the failure is due to material and workmanship defects.
- 1.3.** During the Warranty period, if a defect arises in the Product, ITBE will, at his option and to the extent permitted by law, either (i) repair the Products using either new or refurbished parts, (ii) replace the Product with a new or refurbished Product that is equivalent or similar to the Product to be replaced, or (iii) refund to Buyer all or part of the purchase price of the Product.

2. WARRANTY LIMITATIONS

2.1. This Warranty does not cover:

- i.** In-home service including, but not limited to, service calls to correct the installation of any Products or to instruct Buyer on how to use or install them.
- ii.** Damage or failure resulting from modification, alteration, misuse or abuse of a Product.
- iii.** Damage caused by a carrier or third party, including resulting from improper handling or shipping of Products, or Products damaged by accident, alteration, misuse, abuse, fire, flood, improper installation, acts of God, neglect, corrosion, modification or mishandling.
- iv.** Factory specified replacement parts or Product replacement when Buyer's Product is used in other than normal, single-family household use, such as a commercial environment or handled in a manner contrary to published user or operator instructions and/or installation instructions.
- v.** Aesthetic damages including scratches, dings, dents or cracks that do not affect the structural or functional capability of the Product.
- vi.** Damage resulting from improper loading beyond the specified maximum weight capacity outlined in the assembly instructions provided with the Product including overloading of hooks, baskets, shelves, cabinets, and other accessories used with the Product.
- vii.** Surfaces damaged due to chemical interaction resulting in corrosion of paint, metal or any treatment or cleaning product that is not recommended by ITBE.
- viii.** Color and other covering materials.
- ix.** Drawers and doors, as they may run tight or lose due to high variation in humidity and temperature in the surrounding atmosphere.
- x.** Replacement keys or locking mechanism.
- xi.** Natural wear and tear of the Product.
- xii.** Any labor costs during the Warranty period.

2.2 ITBE must be notified of any defect and given an opportunity to remedy it; any remedial work carried out by a third party will nullify this warranty.

2.3 The cost of repair or replacement under these excluded circumstances shall be borne by Buyer.



3. PROCEDURE AND EVALUATION

3.1 If Buyer has received a defective Product, Buyer must report the defect by sending an e-mail to To be able to help@itbehome.com make a warranty claim, Buyer must always present proof of purchase send a photo of the defective Product and provide a detailed description of the defect.

3.2 Buyer will receive a confirmatory email with a number code and ITBE will process the report within 2 business days. If the photo sent by Buyer is not enough to determine the cause of the Product defect, ITBE may request further explanation, carry out an on-site examination of the Product or require Buyer to send the Product to the nearest support center. If an on-site examination is necessary, Buyer must grant free direct access to ITBE's technician as needed.

3.3 If there is any doubt about whether the problem with the defective Products falls under the Warranty, the burden of proof of the existence of material and workmanship defects lies with Buyer.

3.4 Warranty services will be provided only if a material or workmanship defect is demonstrated, and the defect does not fall under clause 2.

3.5 After evaluation, ITBE will, on its discretion, either repair or replace the defective parts of the Product or the Product itself or refund the purchase price to Buyer. ITBE shall provide Buyer with a forecast of the time required for the repair or replacement of the Product.

3.6 If a product or its part has to be replaced and that particular product or part is no longer available, ITBE reserves the right to use an alternative similar product or part.

3.7 When a warranty claim is justified, ITBE will pay for shipping expenses for repairing or replacing the Product. ITBE can charge Buyer for returned Products that are not found to be defective or non-conforming, in addition to shipping-test, and handling costs associated therewith.

3.8 The warranty does not cover any costs associated with installation, removal or reinstallation of a Product, when applicable.

4. WARRANTIES AND DAMAGES

4.1 To the extent permitted by law, the Warranty and remedies set forth above are exclusive and in lieu of all other warranties and remedies. ITBE specifically disclaims all statutory or implied warranties, including, but not limited to, warranties of merchantability, fitness for a particular purpose and against hidden or latent defects.

4.2 ITBE DOES NOT PROVIDE, AND SPECIFICALLY DISCLAIMS, ANY OTHER WARRANTIES FOR THE PRODUCTS, EXPRESS OR IMPLIED, INCLUDING ANY IMPLIED WARRANTY OF MERCHANTABILITY OR FITNESS FOR A PARTICULAR PURPOSE. ITBE SHALL NOT BE LIABLE FOR OR OBLIGATED IN ANY WAY TO PAY CONSEQUENTIAL OR INDIRECT DAMAGES, INCLUDING, WITHOUT LIMITATION, LOSS OF PROFITS, FINES OR LEGAL ACTIONS BY THIRD PARTIES. IN ANY EVENT, ITBE'S LIABILITY AS RELATED TO THE SUPPLY OF THE PRODUCT SHALL NOT EXCEED THE AMOUNT EFFECTIVELY PAID BY THE BUYER.

4.3 ITBE is not obliged to notify any Buyer, or future Buyer, after a certain date about any possible amendments or the non-applicability of this limited warranty regarding the supplied Products. The Warranty as described below is subject to the limits and other conditions described herein.



Keep this booklet and your proof of purchase together for future reference. You will need to provide proof of purchase to obtain service under warranty.

Write the following information regarding your Product to help you get Better assistance or service should you ever need it.

You should have the complete model number. You can find this information on the label that is located in the package, as an example below:

1234564510000
COPY THIS NUMBER

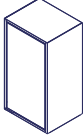
ITBE		PRODUCT IDENTIFICATION	
0001/0003	00000000	00/00/00	1123456411510000
PD 1P-35 ITBE EASY FIT BRM/BRM		PACKED SIZE: GROSS WEIGHT: VOL/UNIT:	
 7892946315555		 Assembled Product 13.77" X 25.19" X 11.22" IN	

Distributor name _____
Address _____
Phone number _____
Model number _____
Serial number _____
Date of purchase _____



it  **be**

Taking good care of your cabinet



Important - In order to avoid severe or even fatal injuries, follow the instructions carefully.



Need Help?



Any questions
on the assembly ?

Contact us.

help@itbehome.com

it→be

itbehome.com